

# SCADAfuse iFIX

Protection for your iFIX investment by protecting its network from unauthorized and dangerous activities

SCADAfuse iFIX is an industrial firewall specifically engineered to protect your iFIX network from unauthorized communications and intrusions. It controls who, how and when updates can be implemented and augments the existing application level security of iFIX with a multi-layered security approach.

SCADAfuse iFIX is available in two physical form factors: DIN rail ruggedized enclosure and 1U telco rack server. It works on any iFIX 6.x deployment and no changes to the iFIX installation are required.



## Benefits

- Industrial network firewall specifically engineered to understand iFIX protocol communication patterns and protect iFIX deployments
- Prevents unauthorized communications from reaching iFIX assets
- Allows easier protected access to iFIX 6.x systems
- Maximizes protection for the variety of iClients in use across your deployment
- Ensures unauthorized nodes cannot interact with the rest of the site
- Replacement option for Opshield products which are no longer available

## Cybersecurity Features of SCADAfuse iFIX

SCADAfuse iFIX provides five separate security controls to protect iFIX standalone, SCADA, and view nodes as they interact with each other and the broader OT/IT network.

iFIX Network Risk	SCADAfuse for iFIX Security Protection	Confidentiality Control
Risk from unknown nodes or clients	Immediately alert and stop attempts to add a node which interacts with or modifies iFIX system behavior	Rogue Node Detection
Risk from unauthorized scanning or communications	Prevent network activity from detecting protected nodes. Protect nodes from revealing sensitive information about their configuration	Reconnaissance Detection & Prevention
Risk of accidental reconfiguration or update	Permit only read-type function codes on native iFIX protocols except during admin-defined time ranges	Scheduled Maintenance Enforcement
Risk of very high message rates (DoS)	Automatic blocking of IPs which exceed typical message rates	DoS/DDoS Protection
Risk of fake devices	Direct enforcement of known IP and MAC addresses for trusted iFIX SCADA nodes and clients.	IP Spoofing Protection

# SCADAfuse iFIX Reference Architecture

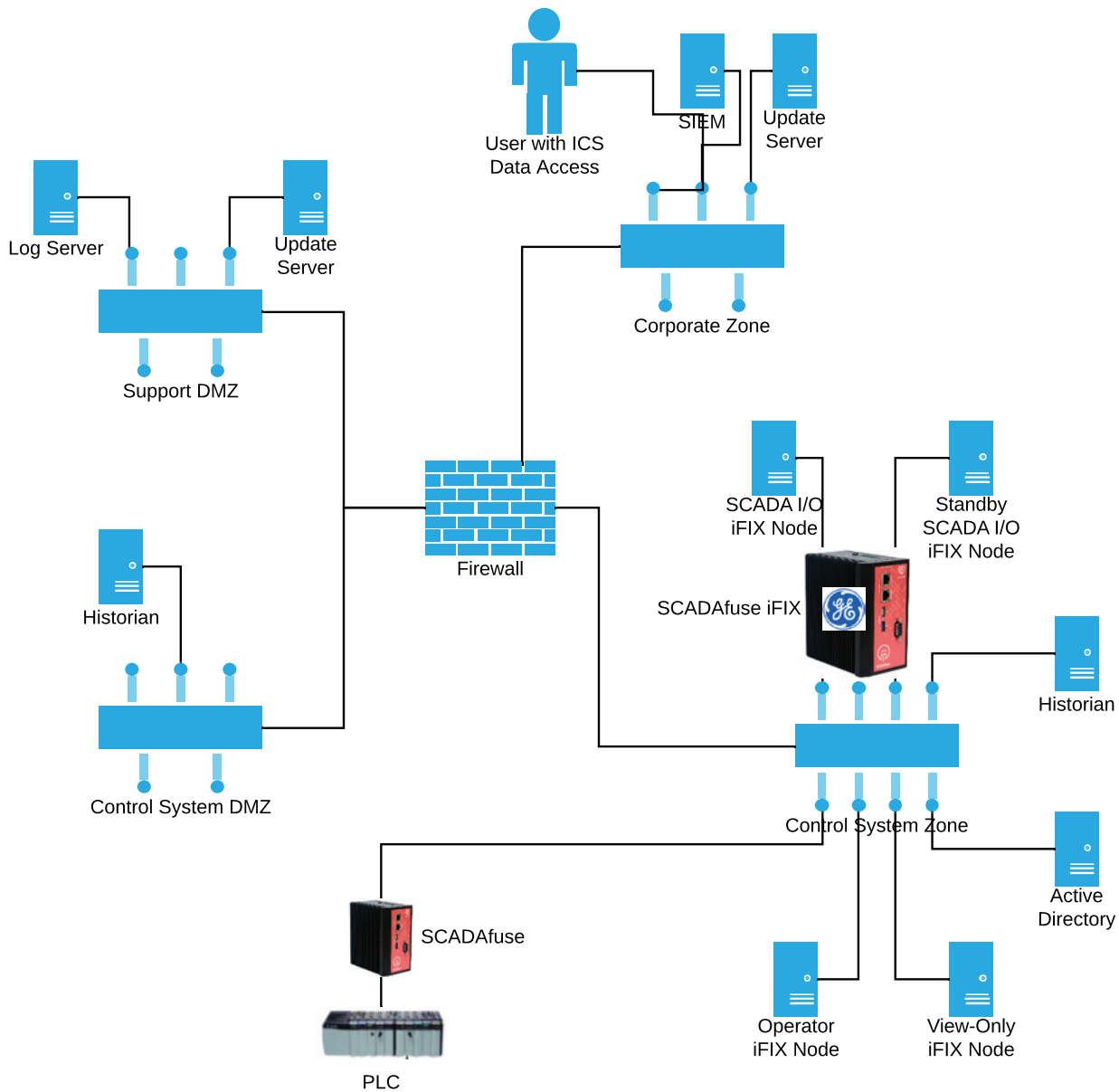

## SUPPORTED PROTOCOL FUNCTIONS

Protocol	Variable Access	Alarm Handling	Session Alarming	Connection Management	Data Transfer	MDBA Handshake
Read Functions	✓	✓	✓	✓	✓	✓
Write Functions	✓	✓	✓	✓	✓	✓